

1000 SERIES GROUND & SURFACE WATER PUMP STATIONS



The 1000 Series ground and surface water pump stations are available in a variety of depths from 1250mm – 3000mm.

- Specifically designed for below ground applications where hydrostatic water pressure may be present.
- Applications include collecting ground water from a Type C cavity drainage system, or surface water from roofs and patios subject to selection criteria.
- Compatible with a range of free standing and guide rail mounted pumps.

SPECIFICATION

- NBS specification R18 (clause 310) Pumping Stations & Pressure Pipelines
- BS 8102:2022 Type C Drainage Protection

PUMP STATION TECHNICAL DATA

Chamber Model	1000 Series
Chamber Material	High Density Polyethylene
Available Depths	1250mm, 1500mm, 1750mm, 2000mm, 2250mm, 2500mm, 2750mm, 3000mm
Available Pumps	V-Series, 500 Series, D10 Series
Inlets	5 x 110mm grommets (supplied loose)
Cable Duct & Vent Size	50mm
Discharge Connection	BSP Class C
Cable Duct Pipework	2" / 50mm White Waste Pipe
Vent Pipework	2" / 50mm White Waste Pipe



INSTALLATION

- A kit is provided so inlets can be easily drilled and sealed on site in the positions highlighted in blue, making this product very simple to install.
- A manhole cover is not supplied as these are generally site specific and installed in the final finish. If required, the chamber will accept a standard 750mm x 600mm cover and frame.

For full installation instructions see '1000 Series Installation Instructions' on our website.

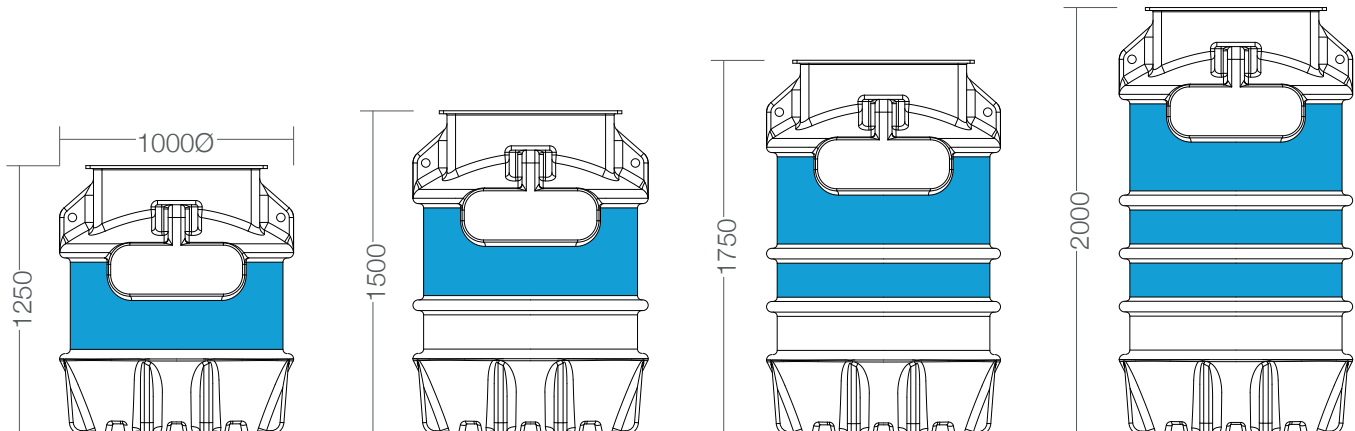

1000 SERIES GROUND & SURFACE WATER PUMP STATIONS



500 SERIES

50Hz - 1 ~ 230V Discharge 2" BSP Female				
Model	P1 kW	P2 kW	In A	Weight Kg
500SA	1.00	0.55	5.0	22
501SA	0.75	0.36	6.0	22
502SA	1.05	0.50	8.2	22
503SA	1.90	1.10	8.2	22
500SM	1.00	0.55	5.0	22
501SM	1.25	0.75	6.0	22
502SM	1.80	1.10	8.2	22
503SM	1.80	1.10	8.2	22
50Hz - 3 ~ 400V Discharge 2" BSP Female				
500TM	0.90	0.55	2.3	22
501TM	1.10	0.75	2.8	22
502TM	1.50	1.10	3.0	22
503TM	2.05	1.50	3.5	22

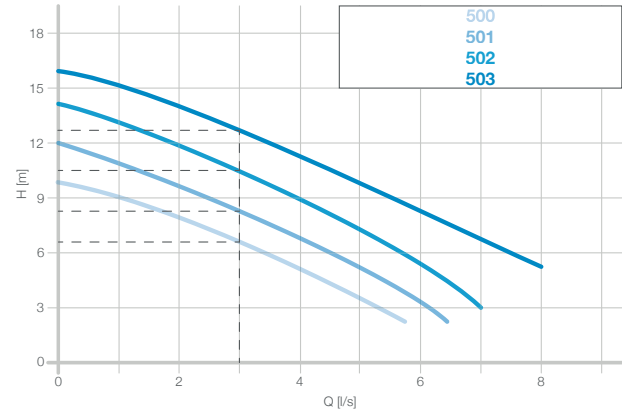

D10 SERIES

50Hz - 1 ~ 230V Discharge 2" BSP Female				
Model	P1 kW	P2 kW	In A	Weight Kg
D10SA	1.14	0.75	5.88	11.95
D10SM	1.14	0.75	5.88	11.95

